

Parts List & Hardware List

Part List	Q'ty	Hardware List	Q'ty
A Hutch	1 pc	1 Screw  #6x5/8"	6 pcs

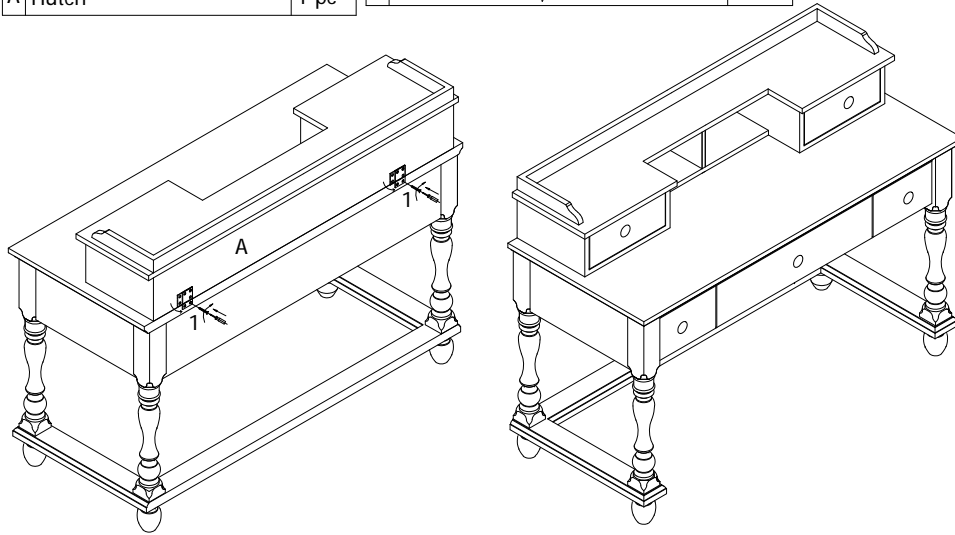





Assembly Procedures:

Step 1: Lay out all parts and hardware. Make sure the quantity of each is correct.

Step 2: The hutch (A) is used with 0850-6101 computer desk. Place the hutch on the desk and align the center mark on back of the hutch with center mark on the desk. Secure the hutch and the desk by using the hardware provided.

Assembly is now complete.

Parts List

Parts List			QTY
A	TOP		1 pc
B	BOTTOM FRAME		1 pc
C	POST		4 pcs
D	BUN FOOT		4 pcs

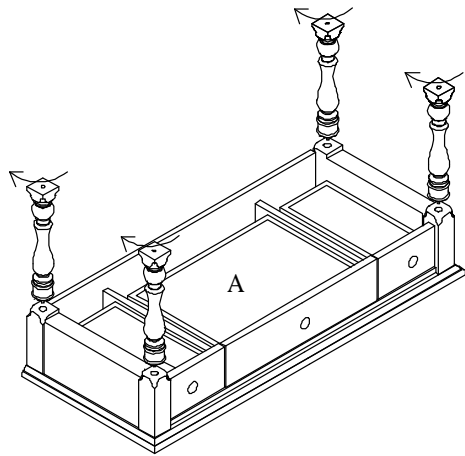

STEP 2

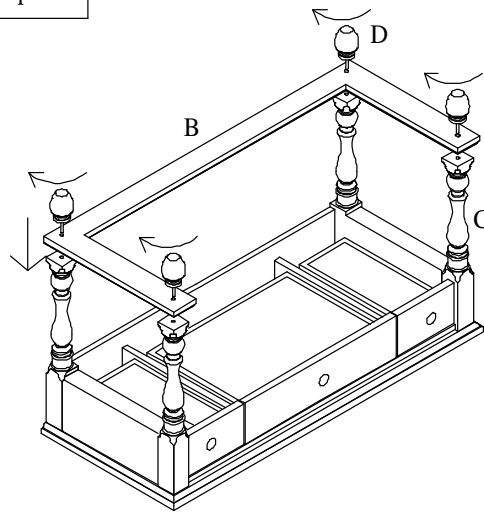

STEP 3

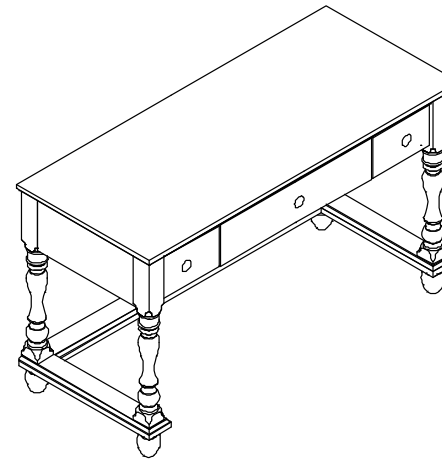

Assembly Procedures:

Step 1: Lay out all parts and hardware. Make sure the quantity of each is correct.

Step 2: Rest the top face down onto a clean soft flat surface such as a blanket and ensure that the surface is clear of any objects that could scratch or damage the top. Assemble the post to the bottom of the top.

Step 3: Place the bottom frame on top of four posts and assemble the bun foot to the post through the bottom frame.

Step 4: Turn the desk to the upright position.

Assembly is now complete.

Assembly Instruction

THANK YOU FOR PURCHASING THIS QUALITY PRODUCT. BE SURE TO CHECK ALL PACKING MATERIAL CAREFULLY FOR SMALL PARTS THAT MAY HAVE COME LOOSE INSIDE THE CARTON DURING SHIPMENT.





CAUTION: (1) THESE PARTS ARE CUMBERSOME AND HEAVY. THIS PRODUCT CAN BEST BE ASSEMBLED WITH THE ASSISTANCE OF ONE OR MORE PERSONS IN ORDER TO PREVENT PERSONAL INJURY AND TO INSURE PARTS ARE NOT DAMAGED DURING THE ASSEMBLY PROCESS. IF DIRTY, CLEAN FINISHED PARTS WITH MILD DISHWASHING LIQUID AND WATER SOLUTION APPLIED ON DAMP CLOTH. CLOTH SHOULD NOT BE EXCESSIVELY WET. POLISH FINISH WITH SOFT CLOTH AND AN INDUSTRY RECOGNIZED FURNITURE POLISH.

(2) TO PREVENT DAMAGE TO YOUR FLOOR OR CARPET, PLEASE CHECK THE BOTTOM OF EACH PIECE OF FURNITURE FOR STAIN RESIDUE AND ROUGH SURFACES AND ALSO CHECK FOR STAPLES OR NAILS LEFT AFTER REMOVING THE PACKAGING MATERIAL. THE MANUFACTURER WILL NOT BE HELD RESPONSIBLE IF PREVENTATIVE STEPS ARE NOT TAKEN PRIOR TO INSTALLATION.

(3) UNPACK AND DISPOSE OF ALL PACKING MATERIAL BUT BE CAREFUL NOT TO THROW AWAY ANY ASSEMBLY PARTS OR HARDWARE. READ THE INSTRUCTION SHEET AND PARTS LIST CAREFULLY. REMOVE ALL STAPLES AND SCREWS USED FOR PACKAGING CAREFULLY USING PLIERS AND OR SCREWDRIVERS TO PREVENT INJURY AND SCRATCHING OR DAMAGING FLOORING.

(4) DURING NORMAL USE EVERYDAY, SCREWS, BOLTS, NUTS AND WOODEN PLUGS MAY LOOSEN UP. THEY SHOULD BE PERIODICALLY INSPECTED AND RE-TIGHTENED TO PREVENT DAMAGE TO THE FURNITURE AND (OR) PERSONAL PROPERTY OR CAUSE INJURY. ALWAYS CHECK TO BE SURE ALL HARDWARE ON THIS LIST AND THE ABOVE MENTIONED COMPONENTS IS ATTACHED TO THE FURNITURE PROPERLY AND KEPT TIGHTENED AT ALL TIMES.

Parts and Hardware List:

Parts List		QTY	NO.	Hardware List			QTY
A	SEAT FRAME	1 PC	#1		1-1/2" L	Bolt+SPRING WASHER+FLAT WASHER--5/16" Dia	2 SETS
B	CUSHION	1 PC	#2		3" L	Bolt+SPRING WASHER+FLAT WASHER--5/16" Dia	4 SETS
			#3		2-1/2" L	Bolt+SPRING WASHER+FLAT WASHER--5/16" Dia	4 SETS
C	BACK FRAME	2 PCS	#4			WOOD SCREW	7 PCS
D	FRONT LEG	1 PC	#5			WRENCH	1 PC

IMPORTANT NOTE:

- 1.USE ONLY THE HARDWARE SUPPLIED.
- 2.DO NOT OVER-TIGHTEN BOLTS
- 3.FIRST READ THE CHAIR LEVELING INSTRUCTION SHEET.

ASSEMBLY INSTRUCTIONS:

STEPS

1. PLACE THE CUSHION (B) UPSIDE DOWN ON A CLEAN, SOFT SURFACE. ASSEMBLE THE SEAT FRAME (A) TO CUSHION(B) USING SCREW (4).
2. REMOVE THE PLASTIC COVER ON THE UPHOLSTERED SEAT . ASSEMBLE THE BACK FRAME (C) TO THE BACK RAIL OF THE SEAT FRAME (A) USING ---- # 1 (BOLT + SPRING WASHER + FLAT WASHER).
3. ATTACH THE REAR CORNER BLOCKS OF THE SEAT FRAME (A) TO THE BACK LEGS AND FRAME (C) USING ---- # 2 (BOLT+ SPRINGWASHER + FLAT WASHER).
4. ASSEMBLE FRONT CORNER BLOCKS OF SEAT FRAME WITH THE FRONT LEGS (D) USING ---- # 3 (BOLT + SPRING WASHER + FLAT WASHER). HAND TIGHTEN THESE BOLTS WITH WRENCH # 5.
5. AFTER MAKING SURE ALL BOLTS ARE ATTACHED AND HAND TIGHTENED, TURN THE CHAIR OVER.
6. LEVEL THE CHAIR FOLLOWING "CHAIR LEVELING INSTRUCTION" .
7. MAKE SURE THE CHAIR IS LEVEL AND THEN TIGHTEN ALL BOLTS COMPLETELY USING THE WRENCH SUPPLIED.

