















Parts List & Hardware List

PARTS LIST			Qty
A		HEADBOARD	1 PC
B		FOOTBOARD	1 PC
C		STORAGE UNIT	1 PC
D		SIDE RAIL	1 PC

HARDWARE LIST FOR PANEL BED			QTY
1	SHORT BOLT	 5/16"×1"	4 PCS
2	LOCK WASHER	 5/16"	8 PCS
3	FLAT WASHER	 5/16"	8 PCS
4	WRENCH	 87# 2mm	1 PC
5	LONG BOLT	 5/16"×1-1/2"	4 PCS
6	WOOD SCREW	 8#1-1/4"	8 PCS

HARDWARE LIST FOR BUNK BED			QTY
1	LONG BOLT	 1/4"×4"	4 PCS
2	SHORT BOLT	 1/4"×2-5/8"	4 PCS
3	ALLEN WRENCH	 4mm	1 PC
4	BARREL NUT		4 PCS

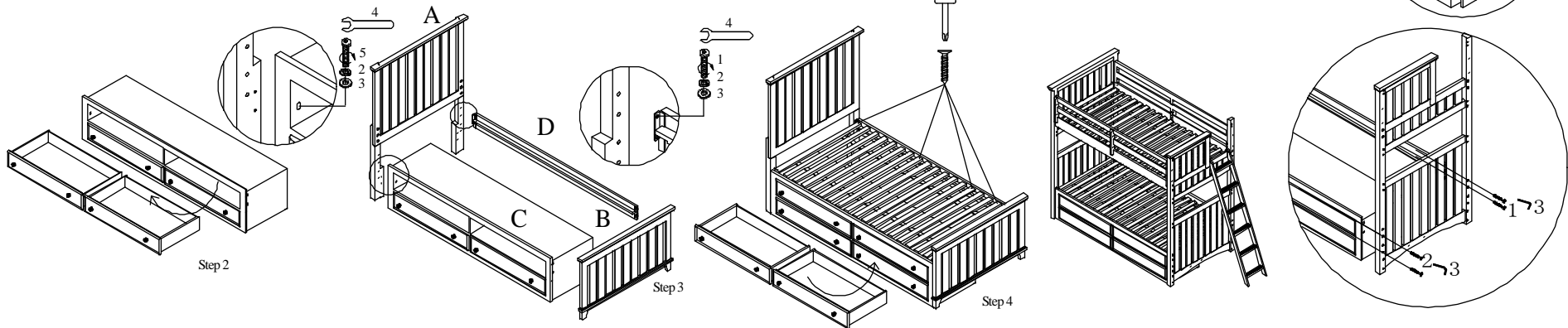

Assembly Procedures:

Step 1: Lay out all parts and hardware. Make sure the quantity of each is correct and the feet are free of stain, staples, screws and nails.

Step 2: Remove the top drawers of the storage unit (C).

Step 3: Assemble the storage unit (C) and side rail (D) to headboard (A) and footboard (B).

Note: If assembling the side rail (D) to bunk bed, please insert the barrel nuts (4).

Step 4: Put the slat roll on the bed cleats, spread out and fasten wood screws. Lastly, install the drawers.

Note: If assembling the storage unit with bunk bed, please use bunk bed hardware.

Assembly is now complete.

ASSEMBLY INSTRUCTIONS:

2960-4105/4115/4901 BED



Thank you for purchasing this quality product. Before beginning, please check the packing material carefully for small parts which may have come loose inside the carton during shipping. Please do not discard any packing material until all parts have been located. If any parts are missing, please contact your dealer for prompt replacement.

Parts & Hardware List:

PARTS LIST			Q'TY	PARTS LIST			Q'TY
A	HEADBOARD		1 PC	E	FOOTBOARD		1 PC
B	BOTTOM STRETCHER		1 PC	F	BED RAIL		2 PCS
C	RIGHT POST LEG		1 PC	G	SLAT		3 PCS
D	LEFT POST LEG		1 PC	H	SUPPORT LEG		3 PCS

HARDWARE LIST			Q'TY	HARDWARE LIST			Q'TY
1	SHORT BOLT	5/16"*1-3/8"	8 PCS	5	LONG BOLT	5/16"*1"	8 PCS
2	SPRING WASHER	5/16"	16 PCS	6	WOOD DOWEL	10*40mm	4 PCS
3	FLAT WASHER	5/16"*19*2mm	8 PCS	7	FLAT WASHER	5/16"*16*1.2mm	8 PCS
4	WRENCH	87*12mm	2 PCS	8	WOOD SCREW	8*1-1/4"	6 PCS

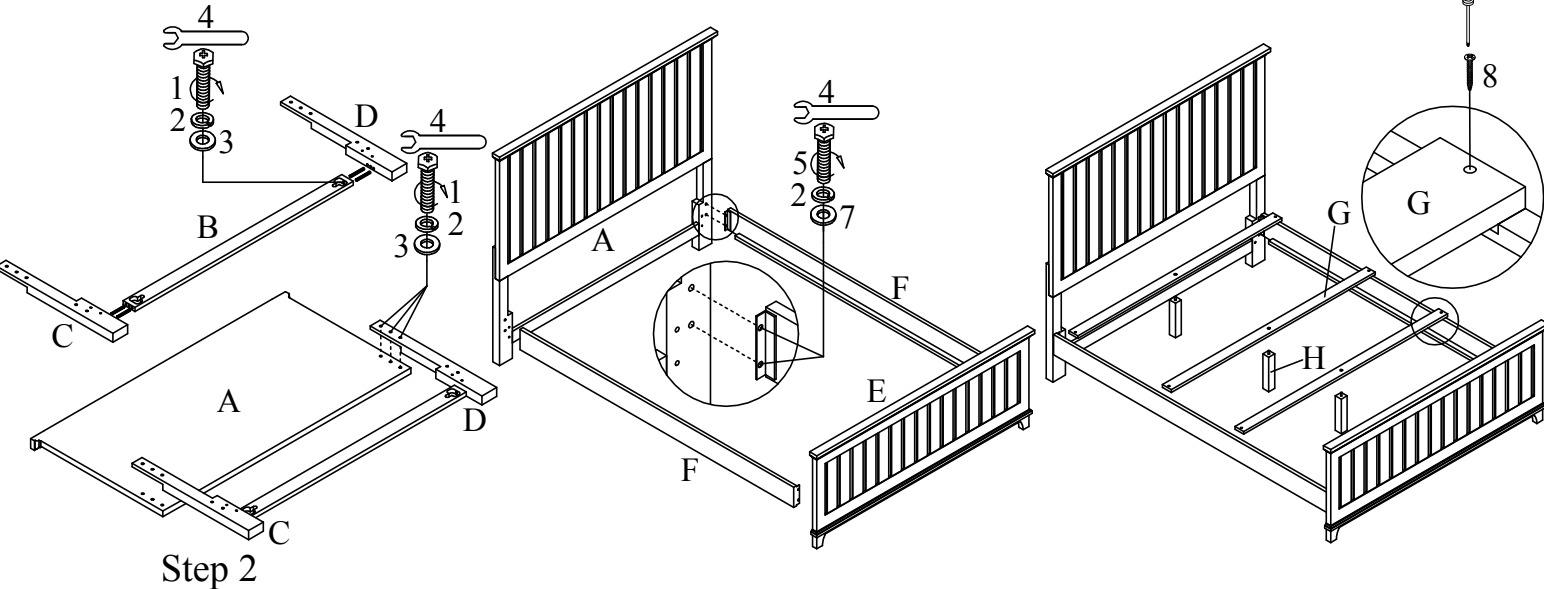

Step 2

Assembly Procedures:

Step 1: Lay out all parts and hardware. Make sure the quantity of each is correct and the feet are free of stain, staples, screws and nails.

Step 2: Assemble the right & left support legs (C&D) to stretcher (B) as shown.



Assemble the right & left support legs (C&D) to headboard (A) as shown.





Step 3: Assemble the bed rails (F) to headboard outer holes (A) and footboard (E) as shown.

Step 4: Assemble the support legs (H) to the slats (G), then assemble the slats to the bed rails as shown.

Caution: Over-tightening screws or bolts may result in damage. It is suggested that at least two people work together for this assembly process to avoid injury. Following assembly, the furniture should be cleaned with a quality, non-silicone furniture polish on a clean, soft cloth.

Parts List & Hardware List

PARTS LIST			Qty
A		HEADBOARD	1 PC
B		Right Leg	1 PC
C		Left Leg	1 PC

HARDWARE LIST			QTY
1	BOLT	 5/16"*1-3/8"	6 PCS
2	LOCK WASHER	 5/16"	6 PCS
3	FLAT WASHER	 5/16"	6 PCS
4	WRENCH	 87*12mm	1 PC

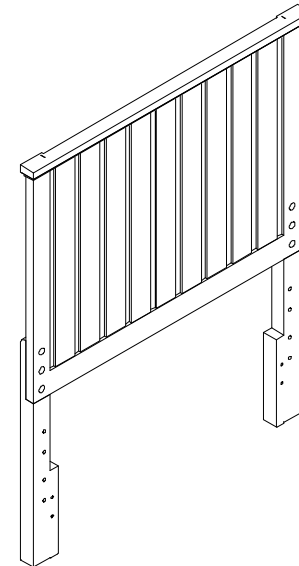
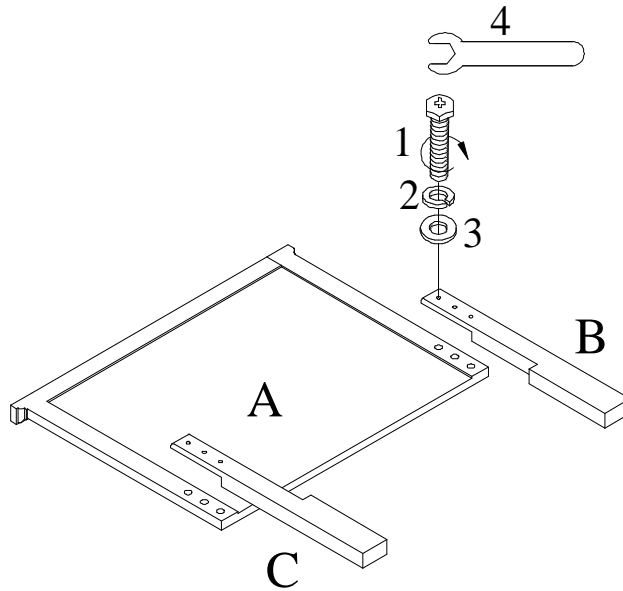

Assembly Procedures:

Step 1: Lay out all parts and hardware. Make sure the quantity of each is correct.

Step 2: Assemble the left & right posts (B&C) to headboard.

Assembly is now complete.