





PART LIST			Q'TY	NO.	HARDWARE LIST			Q'TY
SIDE CHAIR	A	UPHOLSTERY SEAT WITH SEAT FRAME	1PC	#1		1-3/4" L	BOLT + SPRING WASHER + FLAT WASHER-----5/16" Dia	1SET
	B	BACK FRAME	1PC	#2		3-1/4" L	BOLT + SPRING WASHER + FLAT WASHER-----5/16" Dia	4SETS
	C	FRONT LEG	2PCS	#3			NUT + SPRING WASHER + FLAT WASHER-----5/16" Dia	4SETS
				#4			WRENCH	1PC

**CAUTION: (1) THESE PARTS ARE CUMBERSOME AND HEAVY. THIS PRODUCT CAN BEST BE ASSEMBLED WITH THE ASSISTANCE OF ONE OR MORE PERSONS IN ORDER TO PREVENT PERSONAL INJURY AND TO INSURE PARTS ARE NOT DAMAGED DURING THE ASSEMBLY PROCESS. CLEAN FINISHED PARTS WITH MILD DISHWASHING LIQUID AND WATER SOLUTION APPLIED ON DAMP CLOTH. CLOTH SHOULD NOT BE EXCESSIVELY WET. POLISH FINISH WITH SOFT CLOTH AND AN INDUSTRY RECOGNIZED FURNITURE POLISH.**

**(2) TO PREVENT DAMAGE TO YOUR FLOOR OR CARPET, PLEASE CHECK THE BOTTOM OF EACH PIECE OF FURNITURE FOR STAIN RESIDUE AND ROUGH SURFACES AND ALSO CHECK FOR STAPLES OR NAILS LEFT AFTER REMOVING THE PACKAGING MATERIAL. THE MANUFACTURER WILL NOT BE HELD RESPONSIBLE IF PREVENTATIVE STEPS ARE NOT TAKEN PRIOR TO INSTALLATION.**

**(3) DURING NORMAL USE EVERYDAY, SCREWS, BOLTS, NUTS AND WOODEN PLUGS MAY LOOSEN UP. THEY SHOULD BE PERIODICALLY INSPECTED AND RE-TIGHTENED TO PREVENT DAMAGE TO THE FURNITURE AND (OR) PERSONAL PROPERTY OR CAUSE INJURY. ALWAYS CHECK TO BE SURE ALL HARDWARE ON THIS LIST AND THE ABOVE MENTIONED COMPONENTS IS ATTACHED TO THE FURNITURE PROPERLY AND KEPT TIGHTENED AT ALL TIMES.**

**THERE IS ONE BAG OF ASSEMBLY HARDWARE FOR EACH DINING CHAIR.**

**ASSEMBLY PROCEDURES:**

TOOLS REQUIRED: PHILLIPS HEAD SCREW DRIVER AND WRENCH#4(See Hardware List).

CAUTION: PLEASE DO NOT OVER-TIGHTEN BOLTS DURING ASSEMBLY.  
PLACE ALL CHAIR PARTS IN A CLEAN, CUSHIONED AREA.

- STEP 1. REMOVE THE PLASTIC COVER ON THE UPHOLSTERED SEAT(A).
- STEP 2. PLACE THE UPH. SEAT(A) UPSIDE DOWN ON A CLEAN SURFACE OR TABLE.
- STEP 3. ASSEMBLE THE BACK FRAME (B) TO THE BACK RAIL OF THE SEAT FRAME (A) WITH ----#1 (BOLT + SPRING WASHER + FLAT WASHER).
- STEP 4. ATTACH THE REAR CORNER BLOCKS OF THE SEAT FRAME (A) TO THE BACK FRAME (B) WITH ----#2 (BOLT + SPRING WASHER + FLAT WASHER).
- STEP 5. ASSEMBLE FRONT CORNER BLOCKS OF SEAT FRAME (A) TO FRONT LEGS (C) WITH----#3 (NUT + SPRING WASHER + FLAT WASHER).
- STEP 6. AFTER MAKING SURE ALL BOLTS ARE ATTACHED AND HAND TIGHTENED, TURN THE CHAIR OVER.
- STEP 7. LEVEL THE CHAIR FOLLOWING "CHAIR LEVELING INSTRUCTION" .
- STEP 8. MAKE SURE THE CHAIR IS LEVEL AND TIGHTEN ALL BOLTS COMPLETELY.

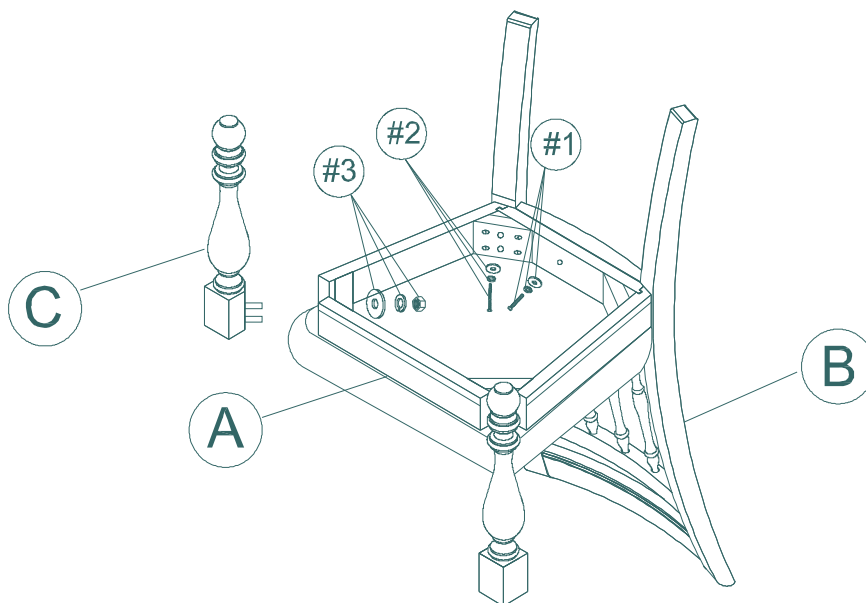

ASSEMBLY IS NOW COMPLETE.

**MADE IN CHINA**